

**Modular Cooking Range Line
 thermaline 90 - Full Induction Top on
 Static Electric Oven, Left Tap, 2 Side,
 Backsplash, H=700**

ITEM # _____

MODEL # _____

NAME # _____

SIS # _____

AIA # _____



589889 (MCJIECK8AO) Full Surface Induction Top on electric static Oven, with left tap, two-side operated

Short Form Specification

Item No. _____

Unit constructed according to DIN 18860_2 with 20 mm drop nose top and 70 mm recessed plinth. Internal frame for heavy duty sturdiness in stainless steel. 2 mm top in 1.4301 (AISI 304). Flat surface construction, easily cleanable. THERMODUL connection system enables seamless worktop when units are connected and avoids soil penetrating. Large multi-coil glass ceramic surface without any "dead" spots allows for quick and easy cleaning. Features 9 power levels with fast deployment to full heating power and very low heat dissipation to the kitchen. Overheat protection switches off the supply in case of overheating. Metal knobs and oven handles with embedded hygienic silicon "soft" grip enable easier handling and cleaning. Electric static oven chamber with 40 mm thick oven door and ribbed enamelled steel base plate. Oven chamber with 2 levels of runners for 2/1 GN shelves to enable simultaneous and faster cooking. Heavy duty thermostat with temperature range up to 300°C, electronic sensor for precise temperature control and manual humidity control in the cooking chamber. Upper heating element can also be used for grilling, with or without ventilating mode.
 IPX5 water resistant certification.
 Configuration: Freestanding, two-side operated with left tap.

Main Features

- Almost the entire surface of the ceramic plate can be used without "dead" spots.
- Fast deployment with full heating power immediately.
- Low heat dissipation to the kitchen.
- Overheat protection: a temperature sensor switches off the supply in case of overheating.
- Pans can easily be moved from one area to another without lifting.
- The large surface multi-coil induction top offers a substantial increase in pan and pot capacity thanks to the seamless transition between individual heating zones, ideal for à la carte operation.
- The smooth glass-ceramic surface can be quickly and easily cleaned, thus providing maximum hygiene.
- IPX5 water resistance certification.
- All major components may be easily accessed from the front.
- THERMODUL connection system creates a seamless work top when units are connected to each other thus avoiding soil penetrating vital components and facilitating the removal of units in case of replacement or service.
- Metal knobs with embedded hygienic silicon "soft" grip for easier handling and cleaning. The special design of the controls prevent infiltration of liquids or soil into vital components.
- 9 power levels.
- Oven chamber to have 2 levels of runners to accommodate 2/1 GN trays and ribbed enamelled steel base plate.
- Heavy duty thermostat with temperature range up to 300°C.
- The upper heating element of the oven can also be used for grilling.
- Manual control of humidity in cooking chamber.
- Electronic sensor for precise temperature control.
- The green led light on the control panel indicates the following functions:
 ON: pot is detected
 OFF: the knob is positioned on "zero"
 SLOW BLINKING: no pot detected
 FAST BLINKING: error, the number of blinks indicates the error code type

Construction

- Control light for each zone.
- 2 mm top in 1.4301 (AISI 304).
- Unit constructed according to DIN 18860_2 with 20 mm drop nose top and 70 mm recessed plinth.
- Flat surface construction with minimal hidden areas to easily clean all surfaces
- Internal frame for heavy duty sturdiness in stainless steel.

Sustainability

- This model is compliant with Swiss Energy



APPROVAL: _____

Efficiency Ordinance (730.02).



Included Accessories

- 1 of Grid, chromium plated, for ovens 2/1 GN PNC 910652

Optional Accessories

- Scraper for cook tops PNC 910601
- Baking sheet 2/1 GN for ovens PNC 910651
- Bottom steel plate 2/1 GN for fire clay plate 800&900 with baking oven PNC 910655
- Fire clay plate 2/1 GN for ovens PNC 910656
- Connecting rail kit, 900mm PNC 912502
- Stainless steel side panel, 900x700mm, freestanding PNC 912512
- Portioning shelf, 1200mm width PNC 912530
- Portioning shelf, 1200mm width PNC 912560
- Folding shelf, 300x900mm PNC 912581
- Folding shelf, 400x900mm PNC 912582
- Fixed side shelf, 200x900mm PNC 912589
- Fixed side shelf, 300x900mm PNC 912590
- Fixed side shelf, 400x900mm PNC 912591
- Stainless steel front kicking strip, 1200mm width PNC 912638
- Stainless steel side kicking strip left and right, freestanding, 900mm width PNC 912657
- Stainless steel plinth, freestanding, 1200mm width PNC 912962
- Connecting rail kit: modular 90 (on the left) to ProThermetic tilting (on the right), ProThermetic stationary (on the left) to ProThermetic tilting (on the right) PNC 912975
- Connecting rail kit: modular 80 (on the right) to ProThermetic tilting (on the left), ProThermetic stationary (on the right) to ProThermetic tilting (on the left) PNC 912976
- Endrail kit, flush-fitting, left PNC 913111
- Endrail kit, flush-fitting, right PNC 913112
- Endrail kit (12.5mm) for thermaline 90 units, left PNC 913202
- Endrail kit (12.5mm) for thermaline 90 units, right PNC 913203
- Insert profile d=900 PNC 913232
- Side reinforced panel only in combination with side shelf, for freestanding units PNC 913260
- Filter W=1200mm PNC 913667
- Stainless steel dividing panel, 900x700mm, (it should only be used between Electrolux Professional thermaline Modular 90 and thermaline C90) PNC 913672

- Stainless steel side panel, 900x700mm, flush-fitting (it should only be used against the wall, against a niche and in between Electrolux Professional thermaline and ProThermetic appliances and external appliances - provided that these have at least the same dimensions) PNC 913688

Front

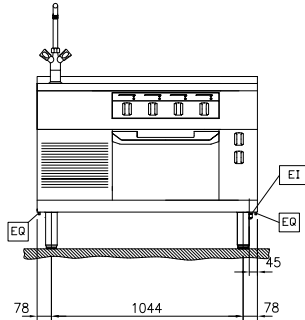

Side

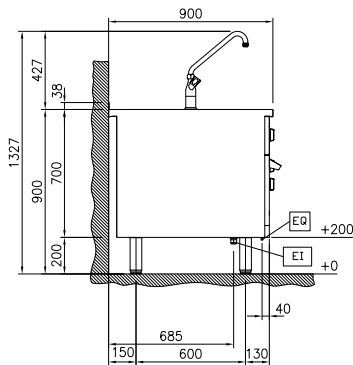

CWI1 = Cold Water inlet 1 (cleaning)
 EI = Electrical inlet (power)
 EQ = Equipotential screw
 HWI = Hot water inlet

Top

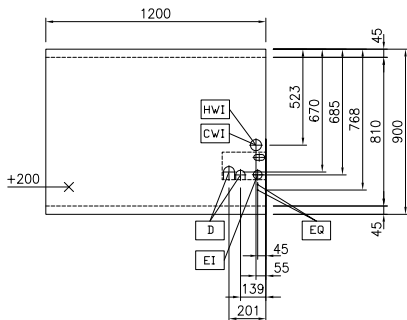

Electric

Supply voltage:
 589889 (MCJIECK8AO) 400 V/3N ph/50/60 Hz
Total Watts: 33 kW

Key Information:

Configuration: Both-Sides Operated; On Oven
Front Plates Power: 7 - 7 kW
Back Plates Power: 7 - 7 kW
Front Plates dimensions: 360x360 360x360
Back Plates dimensions: 360x360 360x360
Oven working Temperature: 60 °C MIN; 300 °C MAX
Oven Cavity Dimensions (width): 575 mm
Oven Cavity Dimensions (height): 300 mm
Oven Cavity Dimensions (depth): 700 mm
External dimensions, Width: 1200 mm
External dimensions, Depth: 900 mm
External dimensions, Height: 700 mm
Net weight: 221 kg
Oven GN: GN 2/1

Sustainability

Current consumption: 51.2 Amps